

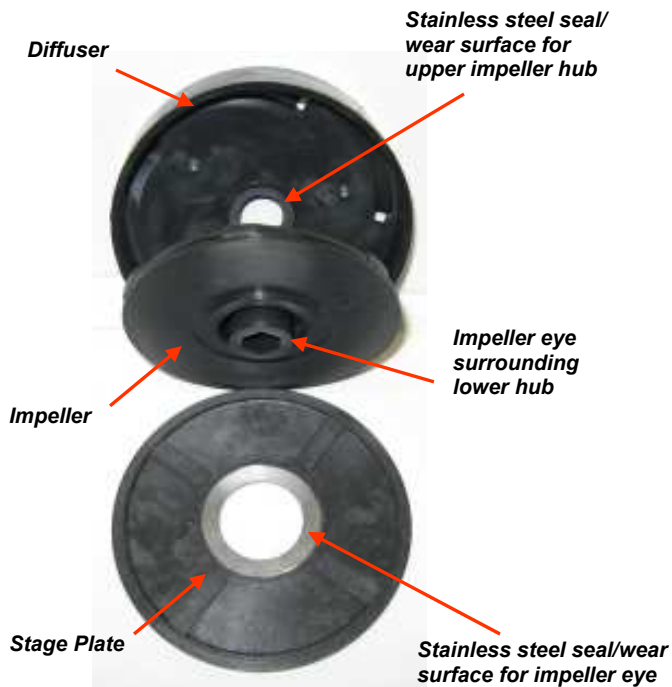

SURVIVOR[®] Submersible Pumps

Lancaster Pump offers a broad selection of SURVIVOR 4" submersible well pumps. Horsepower from 1/2 to 5 HP, with the most popular size range 1/2 to 1-1/2 HP, available in Corrosion Resistant Thermoplastic or Super Strength Stainless Steel. Capacity ratings are 5, 7, 10, 15 and 22 gallons per minute with heads as high as 990 feet.



Inside a pump stage



Laminated phenolic thrust washer on top of every stage provides down-thrust protection and axial sealing for the impeller inside the next stage above



Assembled pump stage

SURVIVOR 4" SUBMERSIBLE PUMP MODEL NUMBER BREAKDOWN

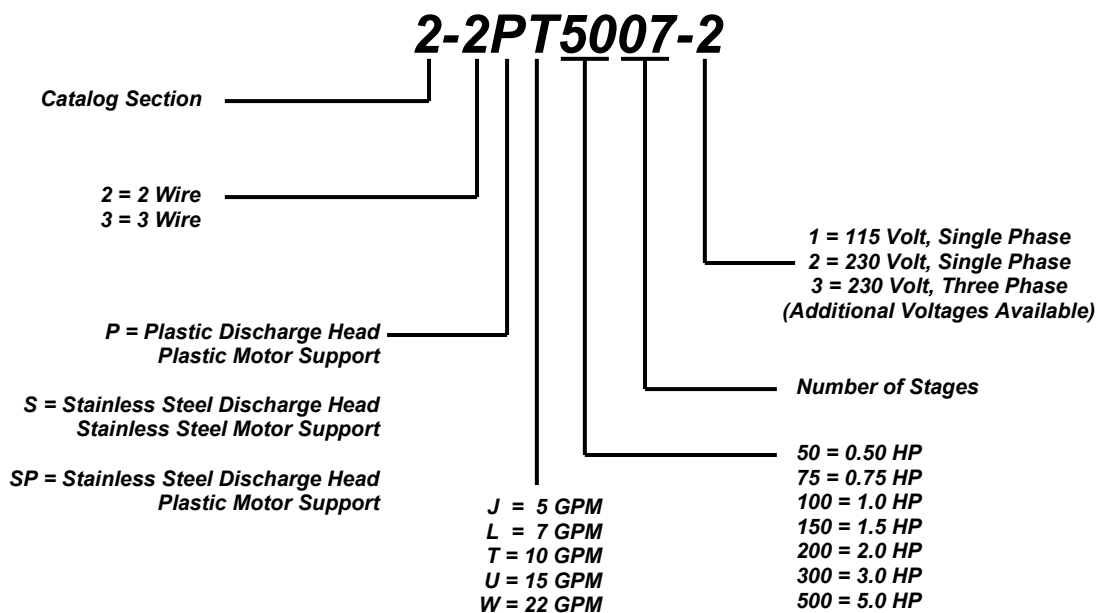

LANCASTER PUMP'S SURVIVOR®

Glass-filled Noryl® **Discharge Head with field replaceable Internal Check Valve.**
Molded jug handles - no need for safety cable adapter, 1/2 HP thru 1-1/2 HP models.
Available in **Stainless Steel** up to 5 HP.



Fluted Polyurethane Bearing at top end of shaft. Excellent abrasion and wear resistance.

Stainless Steel Cable Guard for maximum cable protection. Attached with stainless steel screws.

Balanced Teflon® impregnated **Impellers** made of glass-filled thermoplastic, provide for lower friction for longer pump life.

Stainless Steel Hex Shaft with slotted end for test turning.

Fully enclosed, glass-filled thermoplastic **Diffusers** and **Stage Plates** with stainless steel wear surfaces. Each stage is complete with an individual composite thrust washer for extra protection.

Heavy wall, high quality **Stainless Steel Pump Casing** sized inside for perfect stage alignment.

Glass-filled Noryl® **Motor Support** 1/2 HP thru 1-1/2 HP models.
Available in **Stainless Steel** up to 5 HP.

Stainless Steel Screen, cannot snap off during installation.

Lancaster Pump has teamed up with **Franklin Electric's** super stainless water filled motors, meaning high quality and dependable service.
You can't ask for anything more - just ask for **"Lancaster"!**

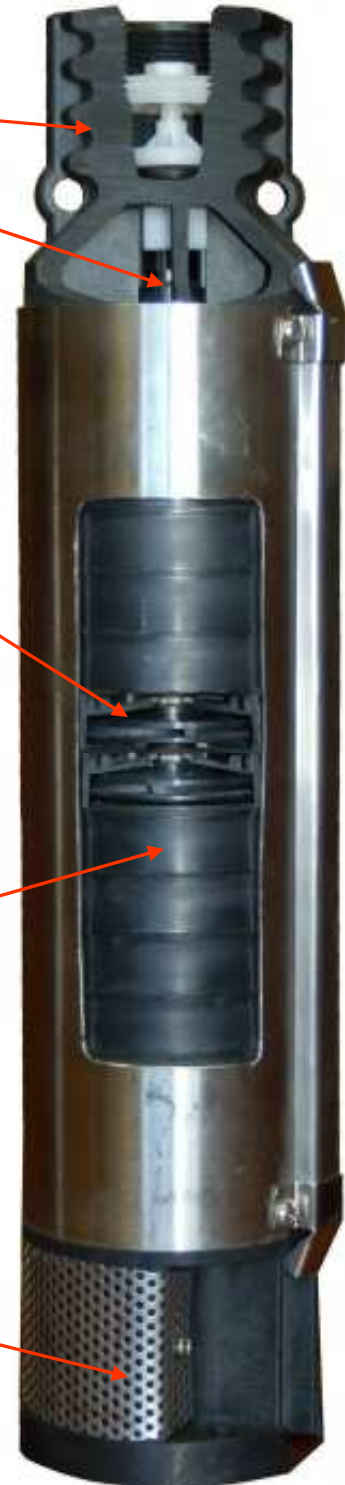

LANCASTER PUMP A DIVISION OF C-B TOOL CO.

1340 Manheim Pike • Lancaster, PA17601-3196 • Fax 717/392-0266 • www.lancasterpump.com