



INSTALLATION, OPERATING AND SERVICE MANUAL

CITY BOSS™

RESIDENTIAL CITY WATER PRESSURE BOOSTER SYSTEM

CITY BOSS™ is a city water pressure booster system utilizing the MASCONTROL® pump controller and a single stage pressure booster pump. The pump controller monitors both flow and pressure, controlling the operation of the pump automatically. The system maintains constant boosted water pressure during operation. No pressure tank or switch required. No adjustment or maintenance is needed.

CAREFULLY READ THE LITERATURE PROVIDED BEFORE INSTALLATION!
Familiarize yourself with the specific details regarding installation and use.
Leave this manual with the system for future reference.

LANCASTER PUMP RECOMMENDS A QUALIFIED PROFESSIONAL TO INSTALL THIS SYSTEM.

INSPECT THE SYSTEM COMPONENTS:

Occasionally, products are damaged during shipment. If a component is damaged, contact the transportation company or your dealer. Save the product's packing materials until the claim is settled. The system package includes pump, pump controller, and rubber grommets. For systems utilizing 1¼ MNPT pump controller, pipe fittings are included to connect pump to pump controller.

SAFETY INSTRUCTIONS

- 1. WARNING – HIGH PRESSURE.** The pump can boost to high pressure. Verify the incoming water pressure **BEFORE** installing the booster system. Make sure the incoming water pressure **plus** the pressure boost developed by the pump is a **SAFE** psi for the application's piping and fixtures. If required, a pressure reducing valve can be installed in line after the booster system to reduce water pressure to a safe level. A pressure relief valve piped to a suitable drain is recommended for overall system protection. Never install or service the pump or system without relieving the internal pressure.
- 2. WARNING – HAZARDOUS VOLTAGE.** Voltage can shock, burn or cause death. Install, ground and wire pump and controller according to local and national electrical code requirements that apply. The pump's single phase motor is equipped with automatic resetting thermal protection. The motor may re-start unexpectedly causing the leads to energize or pump to turn. **DISCONNECT ELECTRICAL POWER SUPPLY BEFORE INSTALLING OR SERVICING THE PUMP.** Capacitor voltage may be hazardous. To discharge motor capacitor, hold insulated handle screwdriver (**BY THE HANDLE**) and short the capacitor terminals together. Do not touch metal screwdriver blade or capacitor terminals.
- 3.** Install the water pressure booster system according to all plumbing code requirements.
- 4.** Pump only water with this system. Pump can be severely damaged if run dry. The pump controller will detect a run-dry condition and shut off the pump. Do not pump water above 120° F, due to internal pump components temperature limitations. Do not allow pump, pump controller, piping or any other system component to freeze. Freezing may damage system, leading to injury or flood.
- 5.** Pipe joint compound can cause cracking in plastics. Use only Teflon tape when sealing threaded plastic pipe or connecting pipe to plastic components such as the pump controller.

PRE-INSTALLATION PREPARATION

MAKE SURE YOU HAVE READ THE SAFETY INSTRUCTIONS PRECEEDING THIS SECTION!

LOCATION- The water pressure booster system (pump and pump controller) should be installed in any convenient location that provides sufficient space for installation and servicing. A clean, dry basement or utility room to avoid dampness and temperature extremes are excellent choices when allowed by law. Check with state and local agencies to determine restrictions in your area. A pressure relief valve piped to a suitable drain is recommended for overall system protection.

PIPE CONNECTIONS- Always follow state and local plumbing codes. Lancaster Pump does not sell or specify pipe types or materials, consult with your pipe supplier to determine the best pipe for your installation. Use Teflon tape on male threads of plastic pipe. Do not use pipe joint compound on plastic piping because it will damage piping (crack) over time. Use minimum $\frac{3}{4}$ " pipe size to the pump inlet. Provide a drain cock at a low point in the service line for draining the system. If the booster system is inactive for any length of time, it is advisable to completely drain the system to prevent freezing. Drain all piping to a point below the freeze line. Remember the pump controller has an internal check valve and will not drain through. Lancaster Pump recommends installing unions or slip couplings on the inlet side of pump and discharge side of pump controller for ease of disconnecting booster system for service or to protect from freezing.

ELECTRICAL CONNECTIONS- Wiring to this booster system must be installed and maintained in accordance with both the National Electrical Code and state /local codes.

Make sure motor voltage rating matches available power supply. See the motor nameplate. Dual voltage motors have a sticker on them that identifies the factory pre-wired voltage. If needed, the motor voltage is changed inside the motor cover. See the motor nameplate for instruction. Make sure the breaker or disconnect is OFF before entering the motor cover.

Properly sized copper wire from service to pump controller will avoid over-heating wire and excessive voltage drop at the motor. Pump controller should be connected to a separate branch circuit with no other appliances on it. Consult dealer or electrician.

UNDERSTAND THE SYSTEMS MAJOR COMPONENTS AND THEIR FUNCTIONS...

BOOSTER PUMP- The pump increases water pressure using an impeller located inside the pump body. The impeller rotates with the motor shaft, drawing water into its center opening. Water exiting the impeller goes to discharge, entering the pump controller. This pump is NOT intended to lift water from a well. Well pumps require a nozzle/venturi device, known as an injector or jet. The booster pump included in the "CITY BOSS" system is not fitted with an injector. The pump is only meant to boost incoming city water pressure.

PUMP CONTROLLER (MASCONTROL)- The MASCONTROL pump controller detects flow demand from an opened tap or valve as low as 0.21 gpm, and energizes the pump to provide constant boosted water pressure until flow demand ends, i.e. tap or valve closed. After the flow demand ends, the pump controller will continue running the pump for 8 to 10 seconds before shutting off, to avoid "quick cycling". The booster system is on "standby" until water is again demanded at the tap. The pump controller will detect irregular operating conditions such as a dry or blocked pump inlet line, and shut off the pump. The red **Failure** light will be on. After the problem is corrected, the user needs only to press and hold the red **Restart** button 3 to 5 seconds (with a tap opened) to restore normal operation. If power is lost, the pump controller will reset and restart automatically when power is restored. Cut-in pressure is 22 psi standard, i.e. if the system pressure drops below 22 psi (possibly due to a leaking toilet valve, etc.) the pump controller will automatically re-pressurize the system. This restart pressure value is indicated on the rear of the device. The pump controller does not require adjustment or maintenance.

Note: Maximum pressure (close-off) generated by the pump (incoming psi + boost) cannot be less than 45 psi.

Note: The column of water between the pump controller and the highest tap must NOT EXCEED 50 feet. If the column of water above the pump controller exceeds 50 feet, reposition the pump controller higher so the water column is less than 50 feet.

MOTOR- The booster pump's motor is a single phase, capacitor start, open drip proof type with a 14/3 SJTW cord set attached for connection to the pump controller. The motor bearings are permanently lubricated, therefore no maintenance is required. The motor is a dual voltage design utilizing a "voltage selector switch" in its rear housing. Use this switch to match the motor voltage setting with the power supply line voltage.

INSTALLATION

ATTENTION: Apply all safety rules dictated by professional standards. Always disconnect power before installing system.

Conduit Connections: Before mounting the "MASCONTROL" pump controller on the booster pump, open the pump controller's electronic box cover by removing the six screws from the cover. Refer to the "MASCONTROL" manual packaged with the "MASCONTROL" pump controller. Press the two rubber grommets (supplied) into the 1/2" conduit connection holes located on the side of the pump controller's electronic box. A flat blade screwdriver may be required to help insert the grommets. "Liquid-tight" non-metallic conduit fittings rated "NEMA 12" or "UL type 12" can be used (not supplied) instead of grommets, to achieve NEMA type 12 enclosure rating. Use of metallic conduit is not recommended.

Figure 1 -

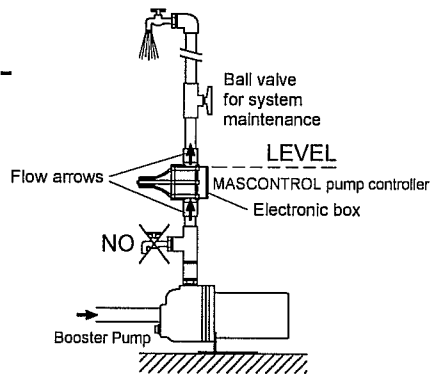

Mounting MASCONTROL pump controller (see Figure 1):

The MASCONTROL may be mounted directly on the booster pump's outlet.
MASCONTROL must be mounted on a vertical column with the electronic box level, and the flow direction arrows pointing upward.
Use only Teflon tape for threaded connections.
Do not install any tap between the pump and the MASCONTROL.

Refer to Figure 2. for detailed system installation diagram.

Figure 2 - "CITY BOSS" Installation Diagram
 City Water Pressure Booster System
 Isolation Bypass Shown

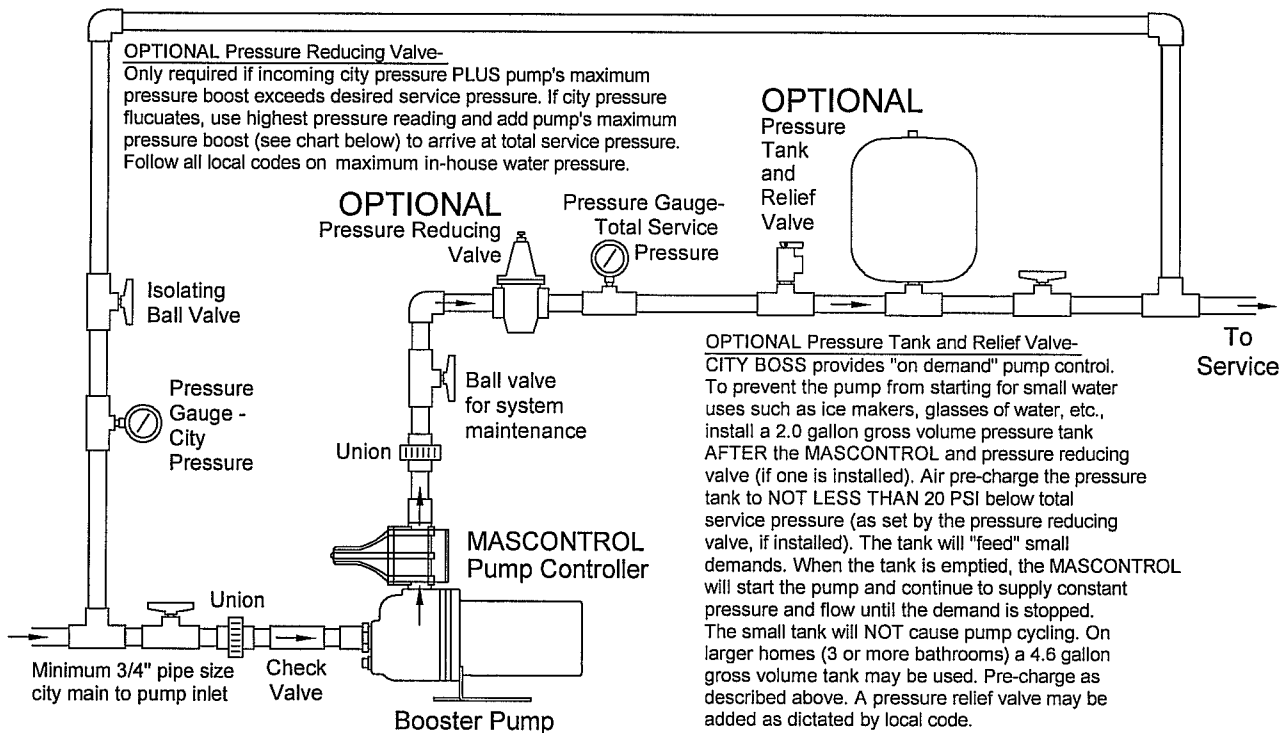

CITY BOSS System	=	Booster Pump	+	MASCONTROL Pump Controller	CITY BOSS Maximum Pressure Boost (at 0 GPM flow)
1-SK50BOSS1		1-SK50		1-BOSS1	39 PSI
1-SK75BOSS125		1-SK75		1-BOSS125	43 PSI

Note:
 Remember that incoming city pressure plus CITY BOSS pressure boost equals service pressure.

Wiring the system: Make sure you have read and understand the SAFETY INSTRUCTIONS concerning HAZARDOUS VOLTAGE and the ELECTRICAL CONNECTIONS portion of the PRE - INSTALLATION section in this manual before proceeding! Refer to Figures 3 & 4 for wiring diagrams. Replace pump controller's electronic box cover, using the six screws, upon completion of wiring the system. If cover is not securely fastened, RESTART button will not operate.

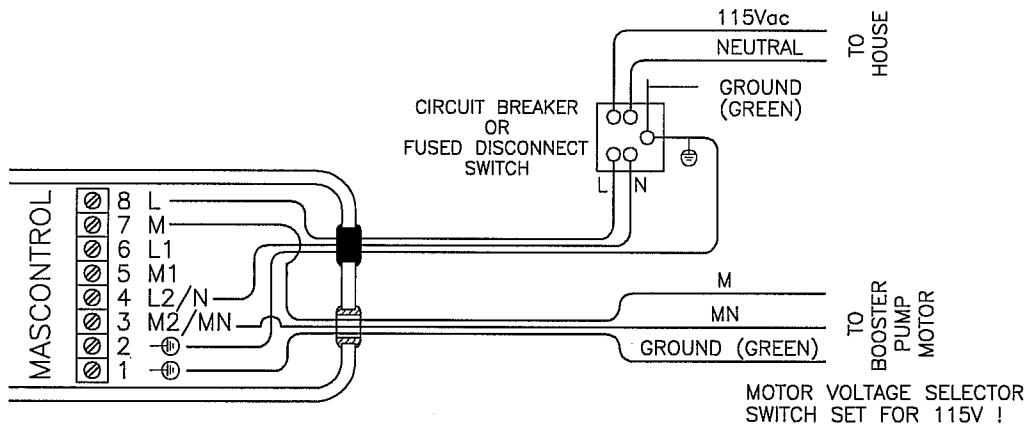

Figure 3 - 115VAC Single Phase Wiring Diagram

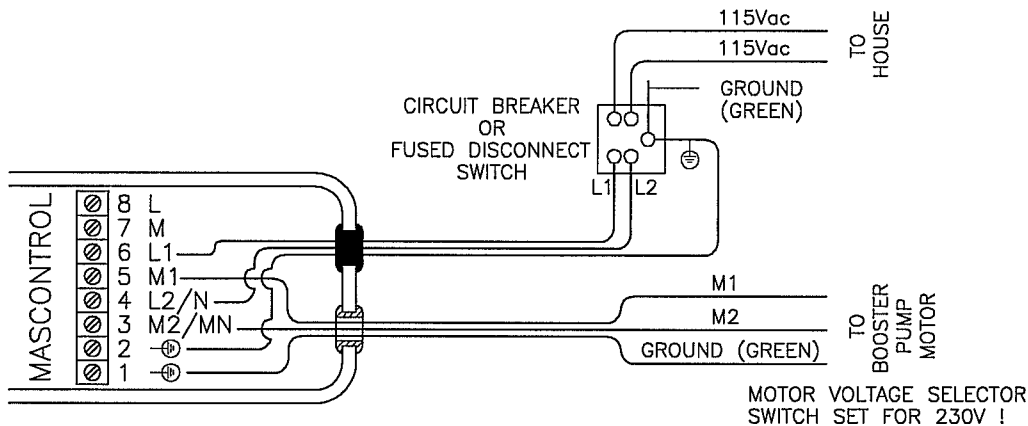
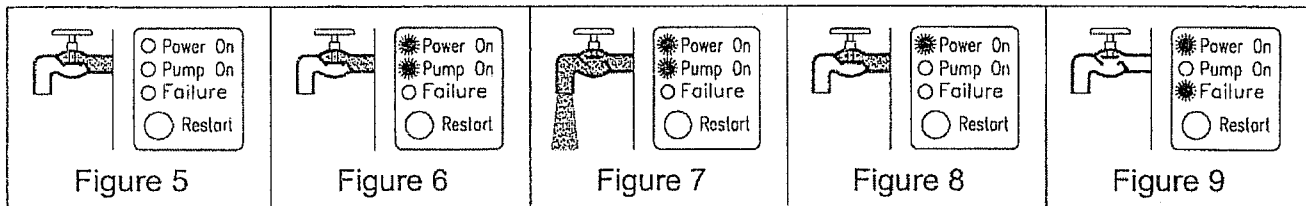

Figure 4 - 230VAC Single Phase Wiring Diagram

START-UP AND OPERATION

After the booster system has been installed by following this manual's installation instructions and diagrams, the city water supply can be released into the booster system, filling the pump and pump controller, etc. with water. If a bypass line was also installed around the booster system, the isolation valve should now be closed (refer to Figure 2). **BEFORE** turning the power supply ON to the pump controller, open the faucet closest to the booster system so air can escape from the system. After air has escaped the system and a steady flow of water occurs, close faucet. When the booster system is first installed, all indicator lights on the pump controller's panel are off (see Figure 5). **NOW** turn the power supply ON to the pump controller. Indicator lights will illuminate and pump will run (see Figure 6). Re-open faucet. If the faucet is not open within approximately 10 seconds, the pump control will simply shut off the pump. Re-open faucet in any case. The green POWER ON light indicates the presence of power in the pump controller, the yellow PUMP ON light indicates that the pump is running (see Figure 7). After the faucet is closed, the pump will shut off after approximately 10 seconds and the pump controller will go to the "stand by" mode with POWER ON light illuminated (see Figure 8). The "CITY BOSS" water pressure booster system is correctly installed and ready to operate automatically.

Using the RESTART Button: If water does not enter the pump and pump controller, the red FAILURE light will illuminate and the pump controller will shut-off the pump within 20-30 seconds. This is the run-dry protection feature, preventing damage to the pumps internal components. See Figure 9. **After** the water supply problem is corrected (is a check valve installed backwards? - did you open valve to allow city water into booster system?), the **RESTART** button must be depressed and held in for a suitable length of time to allow pump to pressurize system, thus overriding the run-dry protection feature. **Do not** override the circuit and run the pump until water supply is confirmed and no pump inlet line obstructions exist.



TROUBLE SHOOTING

NOTE: The pump's single phase motor is equipped with automatic resetting thermal protection. Constant "cutting-out" of this overload device indicates a problem such as low voltage at the motor, excessive temperature in a pump house, etc. This protection is separate and independent of the "MASCONTROL" pump controller. The motor may re-start unexpectedly causing the leads to energize or pump to turn.

WARNING- DISCONNECT ELECTRICAL POWER SUPPLY BEFORE SERVICING THE SYSTEM.

WARNING- RELIEVE INTERNAL WATER PRESSURE BEFORE SERVICING THE SYSTEM.

Although the "MASCONTROL" pump controller can be used with jet pumps on well systems, the "CITY BOSS" pressure booster system pump provided is NOT intended to be used for wells. The booster pump provided is meant to boost city water pressure.

TROUBLESHOOTING

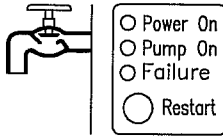

Figure 10

POWER ON, PUMP ON and FAILURE lights all off. Tap opened, no flow, pump off (Fig.10).

Power supply is on but no lights are lit. Turn off power supply to the Mascontrol and remove the electronic box cover. Check all electrical connections to be certain they are tightly fastened to the proper terminals for the voltage needed (115V or 230V). Refer to the schematic in the electronic box. If all electrical connections are secure and correct, test electrical terminals with meter to ensure power is present at all terminals. If power is at the terminals, the electronic box has failed and must be replaced (power must be on to unit to test terminals).

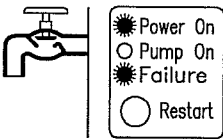

Figure 11

POWER ON and FAILURE light on, PUMP ON light is off. Tap opened, no flow, pump off (Fig.11).

The unit has detected one of the following:

1. Loss of suction - check water supply.
2. Blockage in pipe from water supply to pump and Mascontrol - remove blockage.
3. If a pump has a thermal protection switch, check to make sure the switch has not been tripped by the pump. If pump has been switched off due to the thermal switch, check pump for proper operation and condition and reset thermal switch. Press restart button on Mascontrol. Pump should start up.
4. The pump capacitor has failed or is not adequate.
5. Electronic box failed - replace box (rare occurrence).

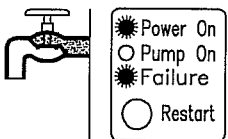

Figure 12

POWER ON and FAILURE light on, PUMP ON light is off. Tap closed, pump off (Fig.12).

1. Pump cannot attain at least 45 psi (incoming psi + boost) at close-off - check pump pressure reading with pressure gauge. Pump must be able to attain at least 45 psi to work properly with Mascontrol unit.
2. Electronic box failure - replace box (rare occurrence).

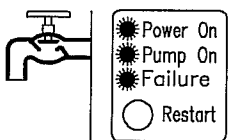

Figure 13

POWER ON, PUMP ON and FAILURE lights are all on. Tap opened, no flow, pump off (Fig.13).

The tap is open and the pump is not operating. Check the wiring in the electronic box to make sure all wires are securely fastened to the proper terminals. Also recheck voltage for correct application (115V or 230V). Press the restart button. If all lights remain on and the pump still does not operate, the electronic box has failed and should be replaced.

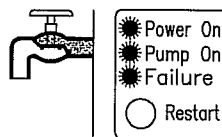

Figure 14

POWER ON, PUMP ON and FAILURE lights are all on. Tap closed, pump on (Fig.14).

The pump is operating and all taps are closed, the electronic box has failed and must be replaced.

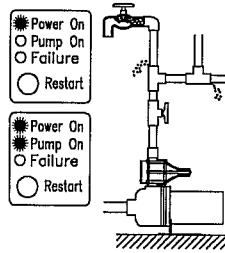

Figure 15

POWER ON light on, FAILURE light off and PUMP ON light short cycles on and off. Tap closed, pump cycles on and off (Fig.15).

1. Leakage less than 0.21 gpm may be present in piping. The higher the leakage rate (but less than 0.21 gpm) the faster the pump cycles. Make sure all taps are closed and all toilet valves are functioning properly. After tap inspection check all piping and valves connected to the system for leakage. To help determine leak location, close the shut-off valve after the Mascontrol. If pump cycling stops, leak is located after the Mascontrol in the water supply. Shut off power to Mascontrol and locate and fix leak. Restore power to Mascontrol (Mascontrol will start the pump automatically) and monitor system to determine that leak has been corrected.
2. If pump cycling still occurs after closing the shut-off valve behind Mascontrol, the bottom check valve is obstructed from closing properly.

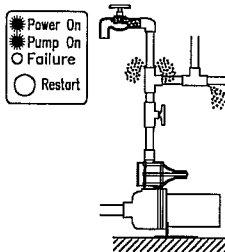

Figure 16

POWER ON and PUMP ON light on, FAILURE light off. All taps closed, pump runs continuously (Fig.16).

1. The condition may be similar to condition 1 (Fig.15) above but leak flow rate is greater than 0.21 gpm. In this case the leak obviously simulates an open tap condition. Follow instructions for condition 1, figure 15 above.
2. The top flow valve to the Mascontrol is obstructed.
3. The electronic box has failed and should be replaced.

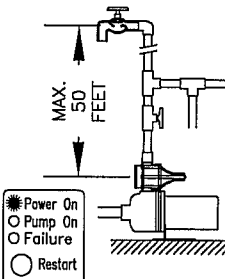
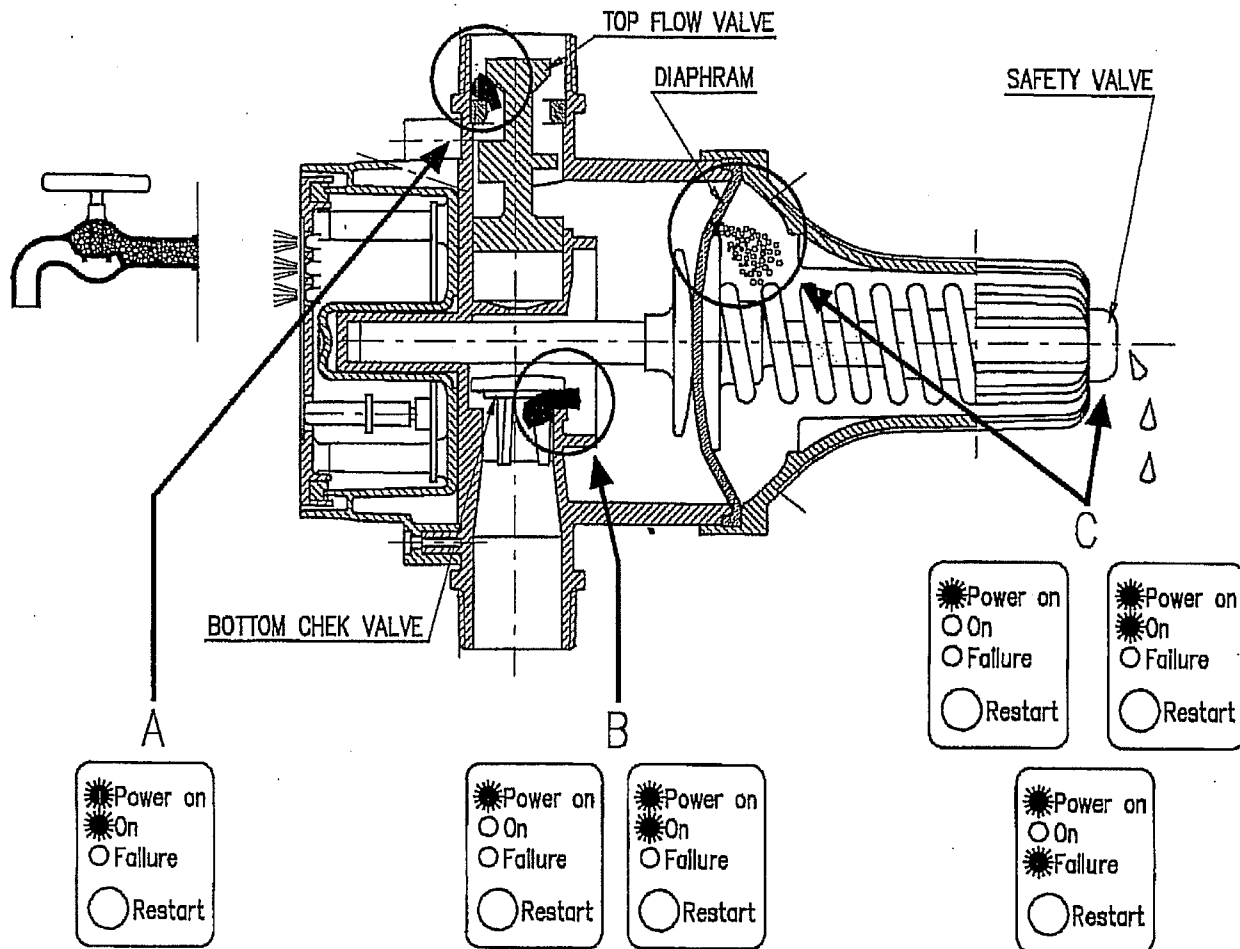

Figure 17

POWER ON light on, PUMP ON and FAILURE light off. Tap open, no flow, pump off (Fig.17).

The column of water between Mascontrol and the highest tap exceeds 50 feet, therefore the column of water has created a pressure higher than the cut-in pressure of Mascontrol (22 psi). This prevents the unit from working properly. Reposition Mascontrol higher so the water column height is less than 50 feet.



A

POWER ON and PUMP ON lights on, FAILURE light is off. All taps closed, pump runs continuously.

The top flow valve is obstructed by metal sediment (from pipe threads etc.) attaching to the magnetic surface of the valve assembly or by natural sediment such as small stones lodging in the valve seat. Open and close the tap quickly several times to remove the sediment. If problem still exist, disconnect the unit, tap on "MASCONTROL" near the top flow valve to free object and allow valve to seat properly. If this does not clear the obstruction, rinse inner cavity with water, dumping out any sediment that may be present. Reconnect the unit, restore power, and monitor for correct operation. Although this condition is rare, service persons and/or installers should note the possibility of sediment obstructions.

B

POWER ON light on, FAILURE light off and PUMP ON light short cycles on and off. Tap closed, pump cycles on/off.

The bottom check valve is obstructed from closing properly by a small stone, filament etc. In this case the cycles are very fast. Disconnect the unit, tap on "MASCONTROL" near the bottom check valve to free object and allow valve to seat properly. If this does not clear the obstruction, rinse inner cavity with water, dumping out any sediment that may be present. Reconnect the unit, restore power, and monitor for correct operation. Although this condition is rare, service persons and/or installers should note the possibility of sediment obstructions.

C

POWER ON light on, FAILURE light off, PUMP ON light turns on and off several times then turns off definitively and FAILURE light comes on. Tap closed, pump cycles a few times and then stops definitively.

The diaphragm is compromised. If a small drop of water appears at "MASCONTROL" safety valve on the end of the unit, the diaphragm has broken and unit must be replaced. This condition is very rare.

LANCASTER PUMP A DIVISION OF C-B TOOL

1340 Manheim Pike ♦ Lancaster PA 17601-3196 ♦ Tel: 717-397-3521 ♦ Fax: 717-392-0266

www.lancasterpump.com ♦ E-mail: info@lancasterpump.com